

SH PLATE LOADED SERIES

SH045 - HORIZONTAL BENCH PRESS



PRODUCT OVERVIEW

The SH045 is a premium plate-loaded strength training machine designed specifically for chest muscle development. With a modern aesthetic and a solid construction, it is ideal for large commercial gyms and upscale personal training studios. The motion path of the press arms is biomechanically engineered to align with the natural fiber direction of the pectoralis major and the shoulder joint's movement trajectory, ensuring a stable, fluid pressing motion that effectively activates the target muscles.

Equipped with oversized rubber-coated handles, the machine accommodates the natural hand positioning of pressing exercises, reducing wrist stress while improving grip comfort and motion control. The ergonomically contoured back pad offers solid support to the torso and scapulae, enabling users to maintain optimal posture throughout the movement, ensuring more precise muscle engagement and safer, more effective training.

SPECIFICATIONS & KEY FEATURES

Specifications

Dimension:	1906*1713*960mm
Net Weight:	115kg
Max Load Capacity:	300kg[2x150kg]
Main Frame Tubing:	PT60x120x2.5
Standard Color Scheme:	SH Series standard color scheme

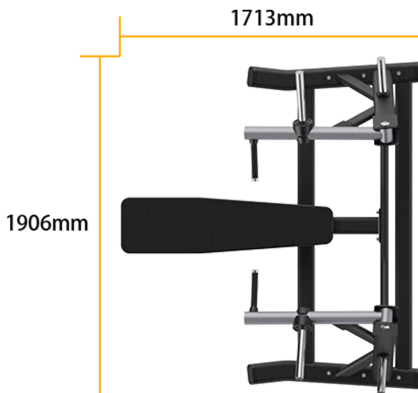
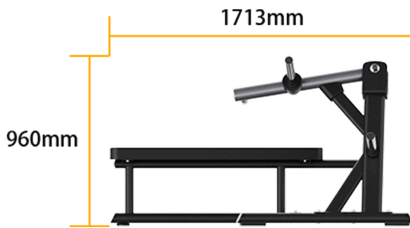

Product Features



Biomechanically Aligned Press Path

Scientifically designed arm trajectory mirrors the natural muscle fiber direction and shoulder movement, optimizing pectoral muscle activation.



Oversized Rubber-Coated Handles

Provide a comfortable grip, reduce wrist strain, and enhance control and safety during pressing exercises.



Ergonomic Back Pad Support

Offers firm support for the torso and scapulae, maintaining proper posture and ensuring efficient force output.



Heavy-Duty Construction

Built with premium materials and precision engineering to ensure long-lasting stability and durability under heavy, frequent use.